

REV	DESCRIPTION	DRAWN	DATE

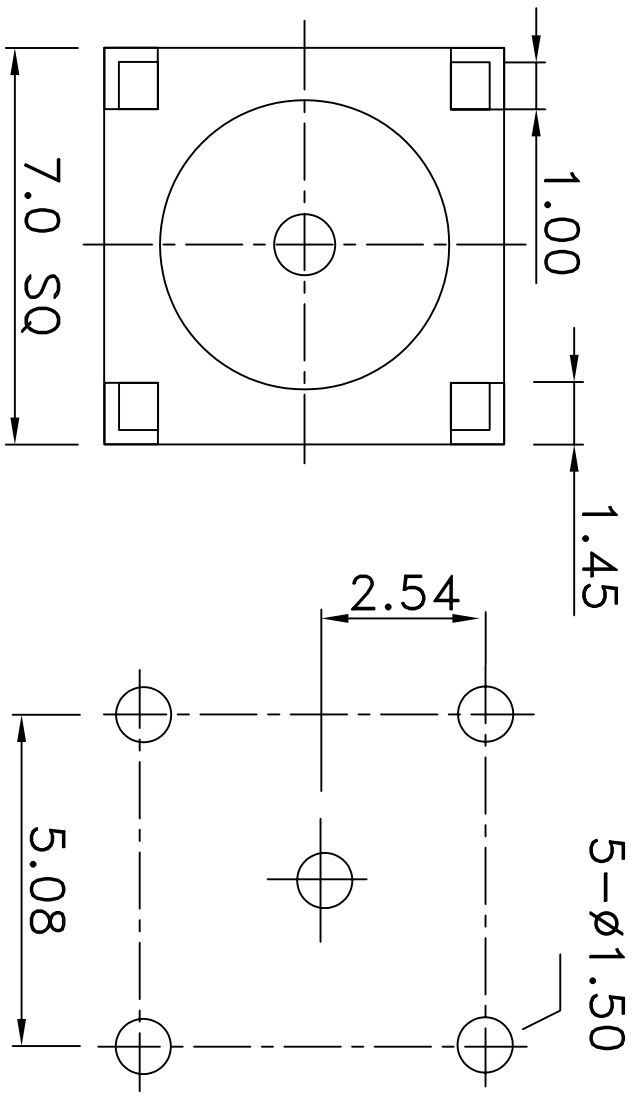
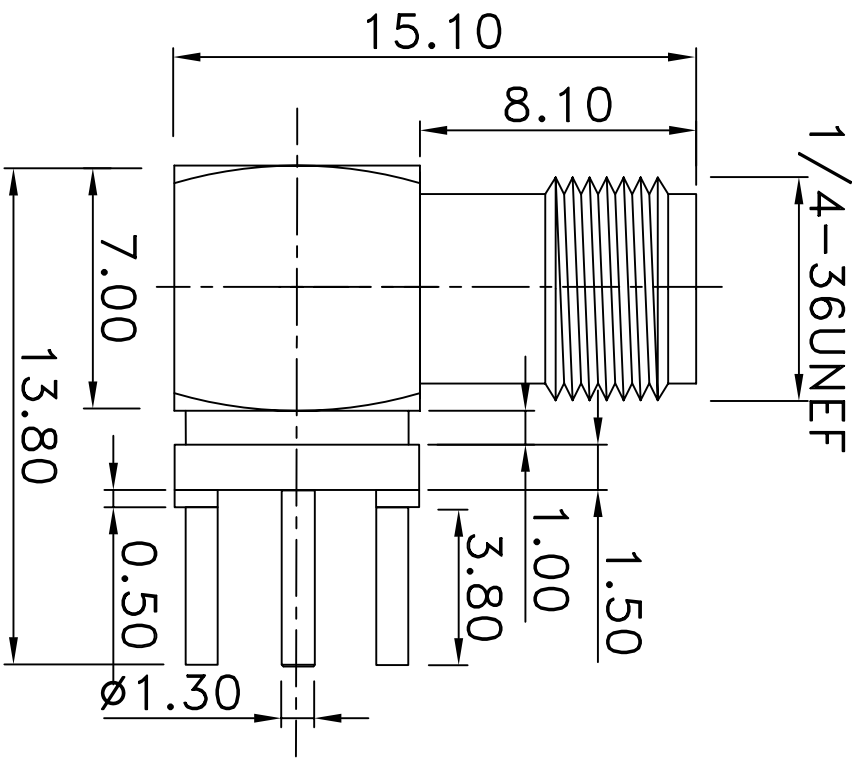

RECOMMENDED HOLE

NO	Description	Qty	Material	Finish
6	CHASDIS	1	BRASS	GOLD
5	INSULATOR B	1	TEFLON	NONE
4	PIN	1	Be Cu	GOLD
3	INSULATOR A	1	TELFON	NONE
2	WASHER	1	BRASS	GOLD
1	BODY	1	BRASS	GOLD

UNLESS OTHERWISE SPECIFIED
 1 REMOVE ALL BURRS
 2 BREAK ALL CORNERS & EDGES TO 15° MAX.
 3 CHAMFER 45° & LAST 4 DIAMETERS ON COMMON CENTERS.
 TO BE CONCENTRIC WITHIN 0.1 TIR
 5 ALL DIMENSIONS ARE AFTER PLATING.

* MAJOR DIMENSION
 UNLESS OTHERWISE NOTED
 TOLERANCES
 0.5-6 = ±0.2
 6-30 = ±0.4
 30-120 = ±0.6
 120-315 = ±1.0
 ANGLES = ±1°

APPROVED
 CHECKED
 DRAWN
 andrew

DRAWN DATE 03/06/27
 FILE NO.
 SMA JACK RIGHT ANGLE P.C.B. MOUNT
 DRAWING NO. SMA-02-34-TGG
 REV A

