

# CASE DRAWINGS

\*Dimensions in inches and (millimeters)

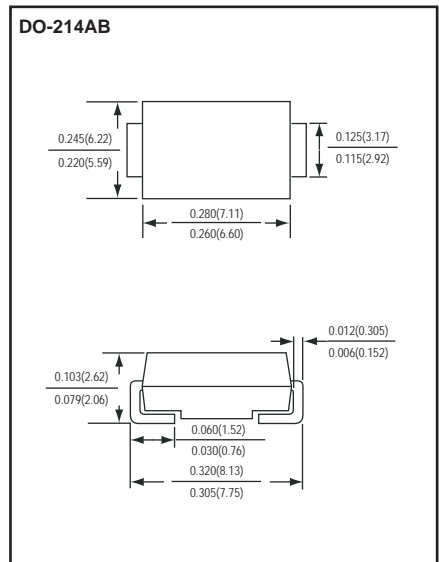
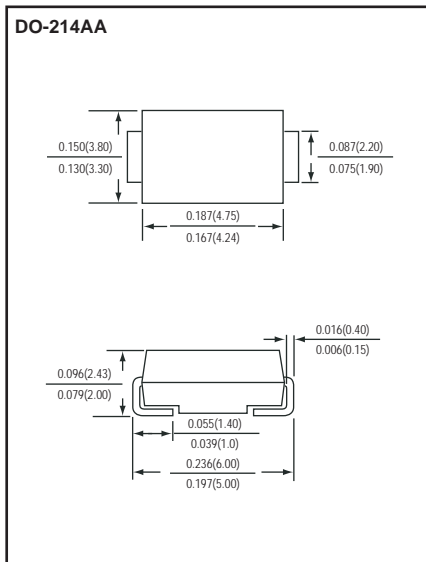
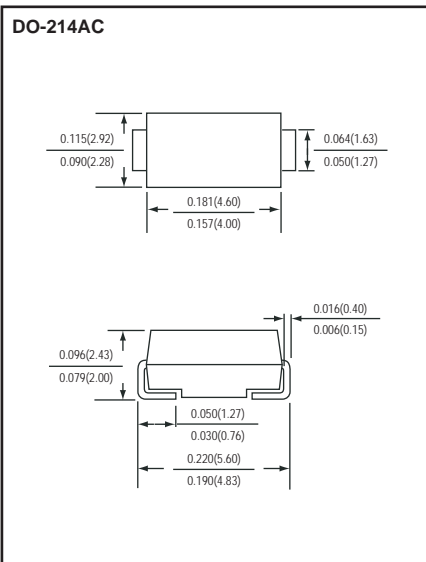
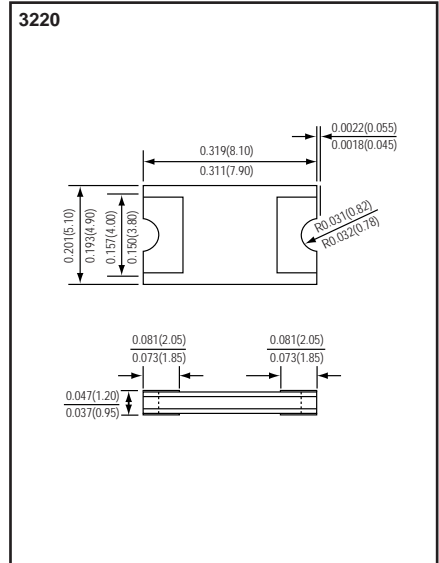
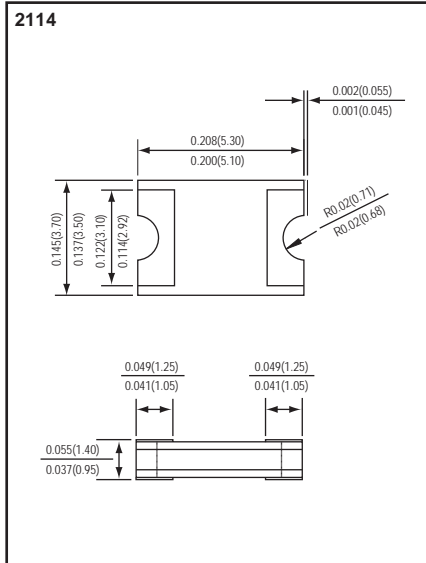
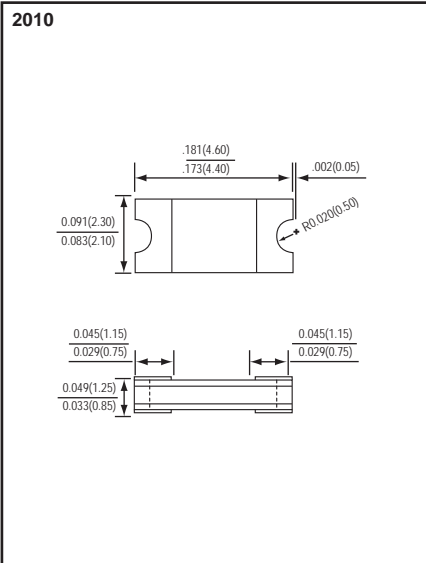
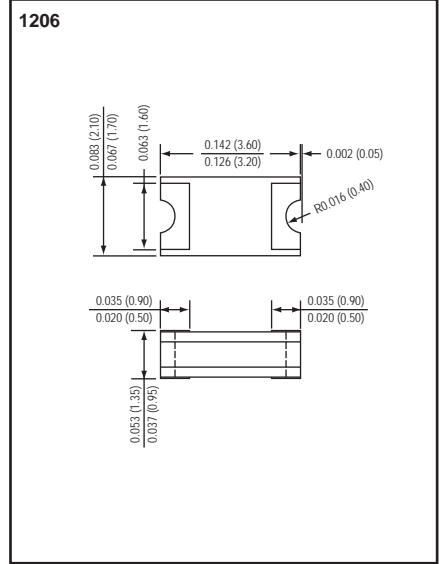
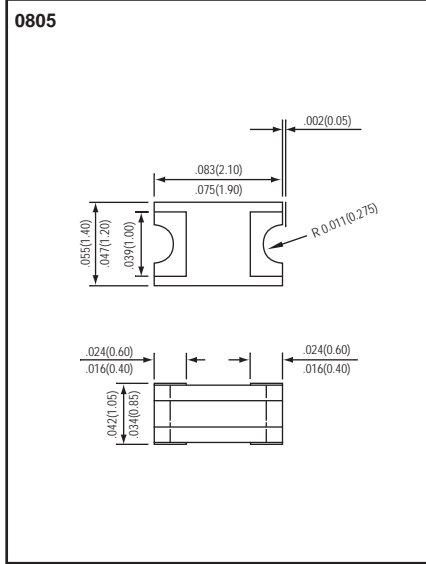
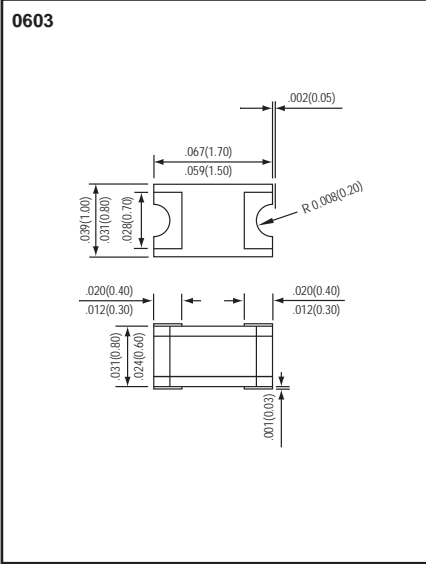

# CASE DRAWINGS

\*Dimensions in inches and (millimeters)

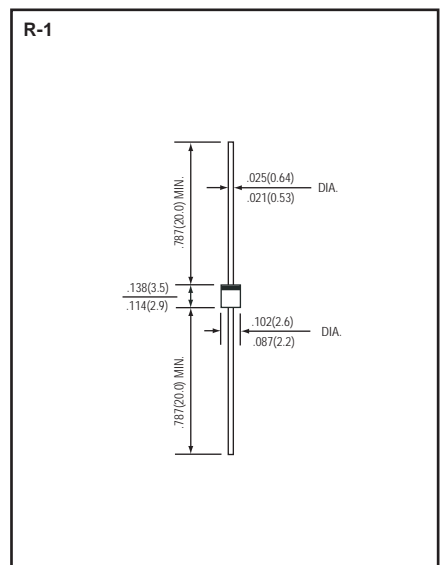
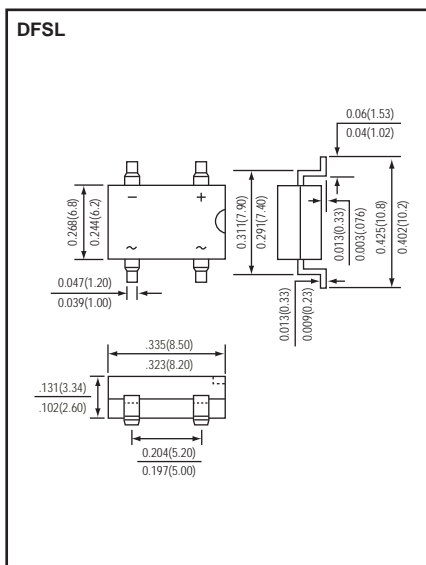
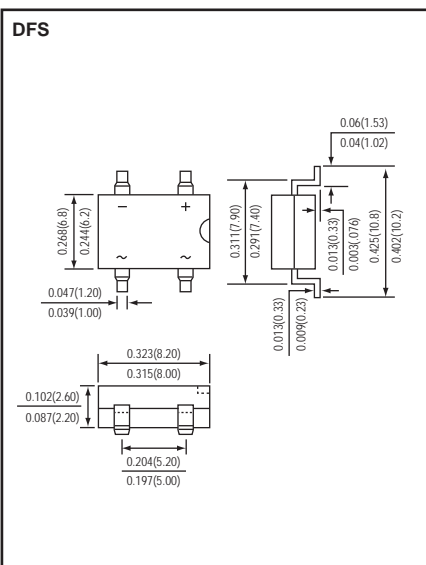
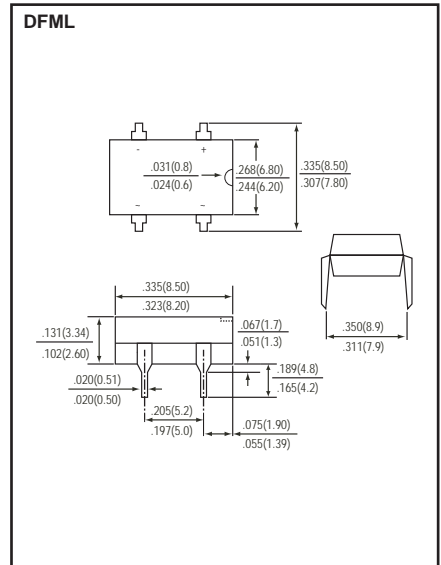
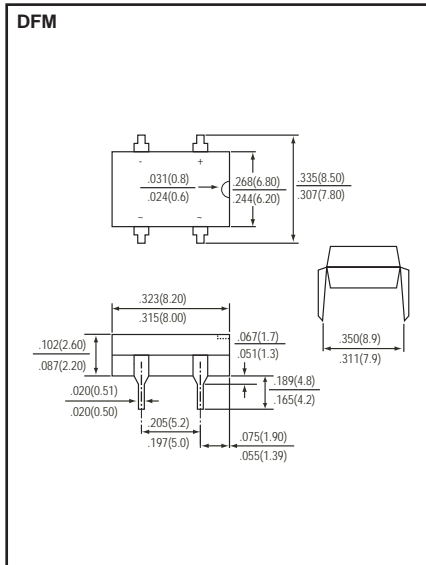
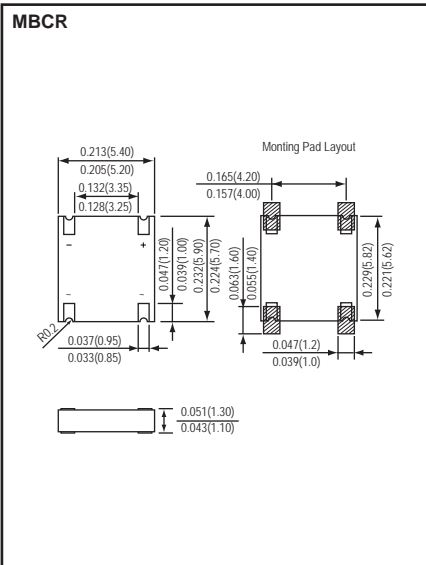
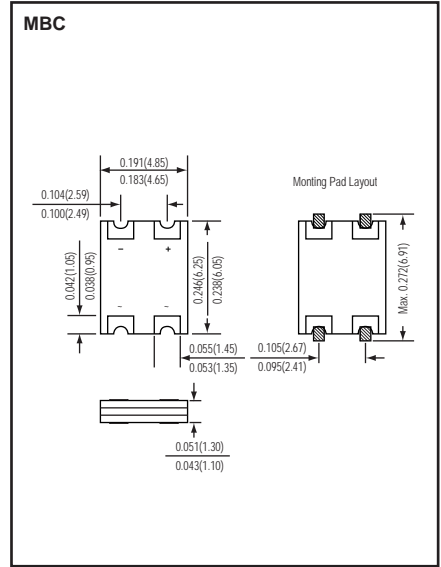
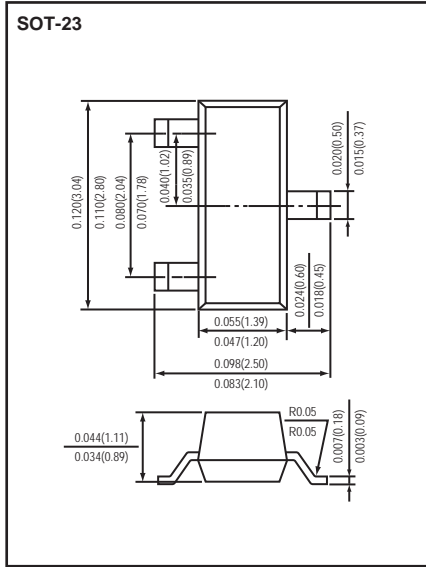
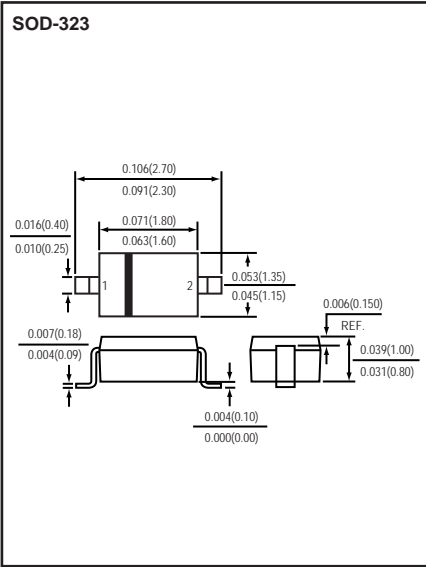

# CASE DRAWINGS

\*Dimensions in inches and (millimeters)

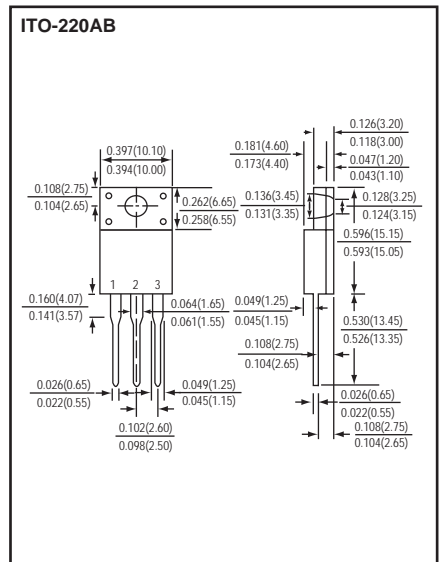
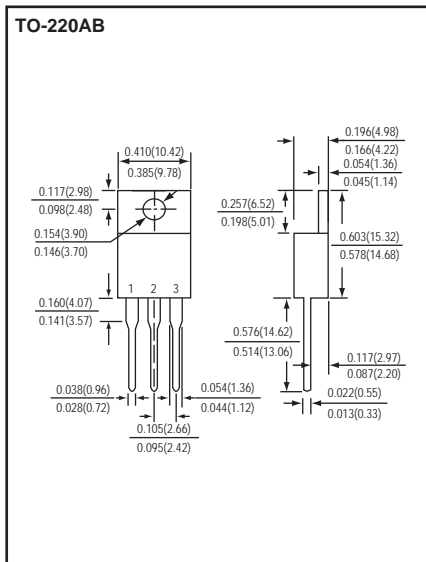
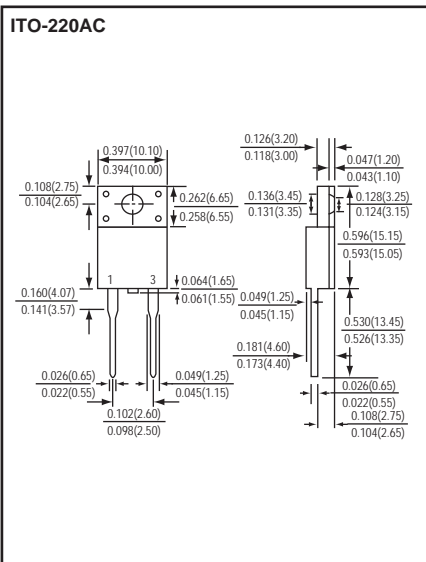
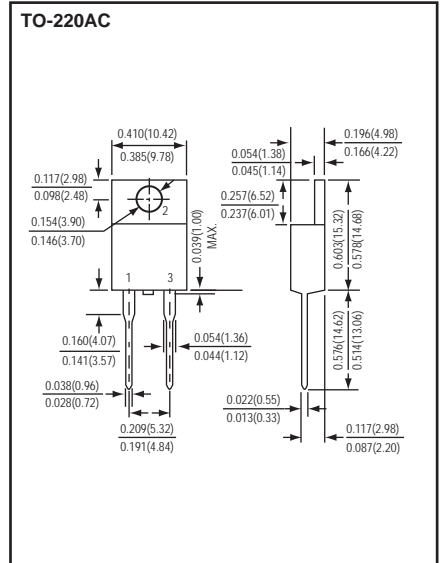
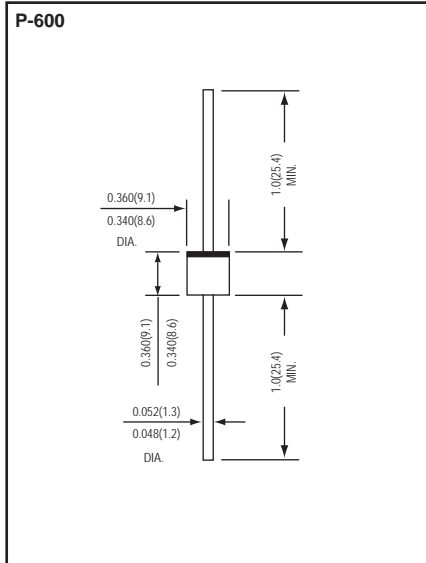
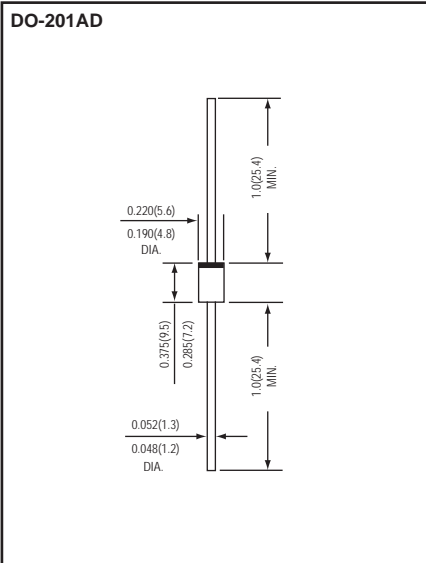
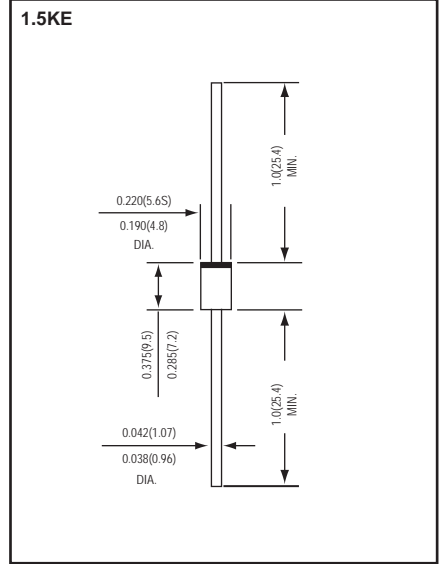
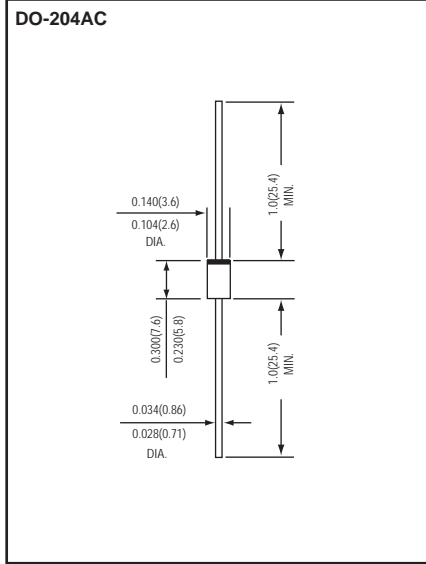
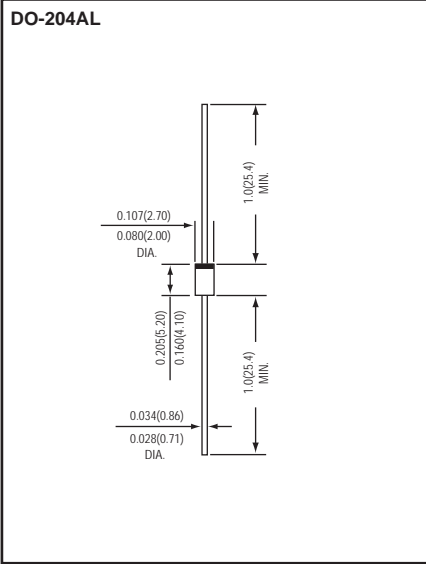

# CASE DRAWINGS

\*Dimensions in inches and (millimeters)

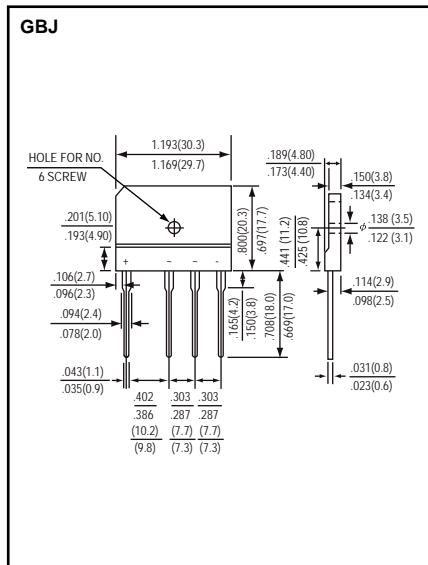
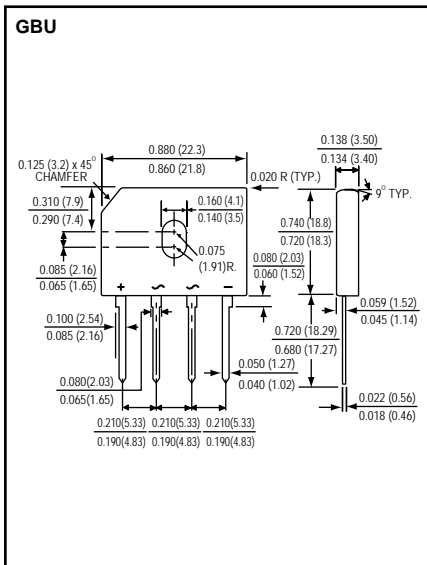
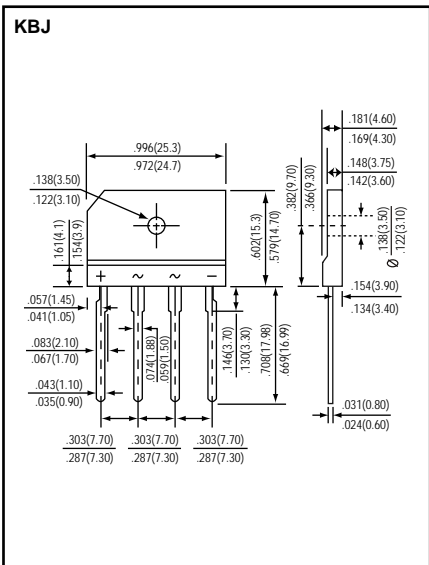
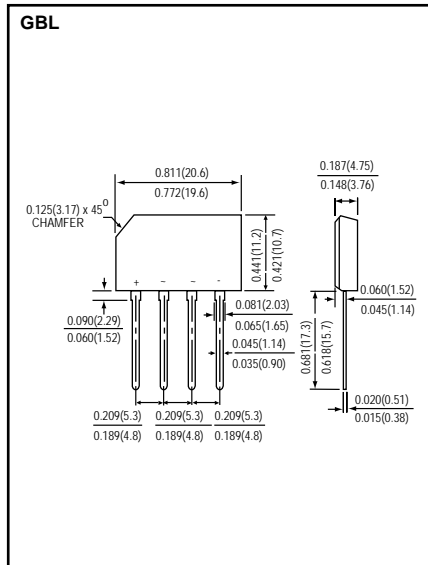
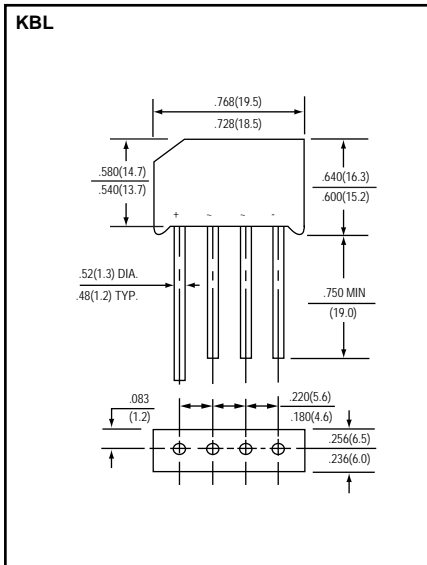
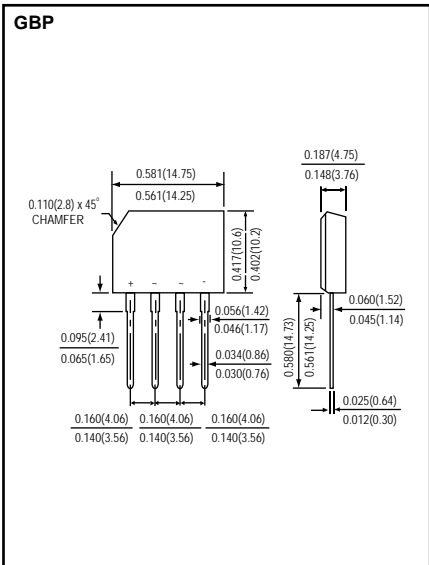
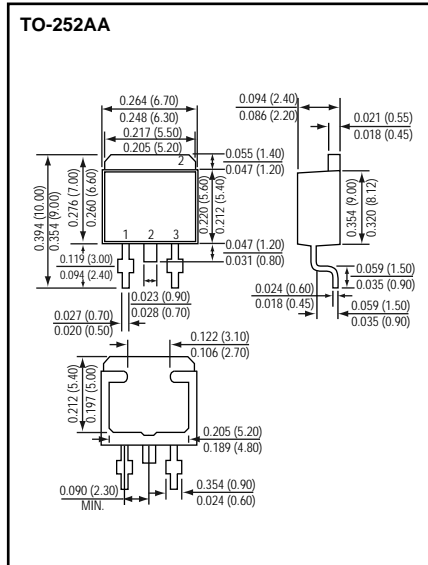
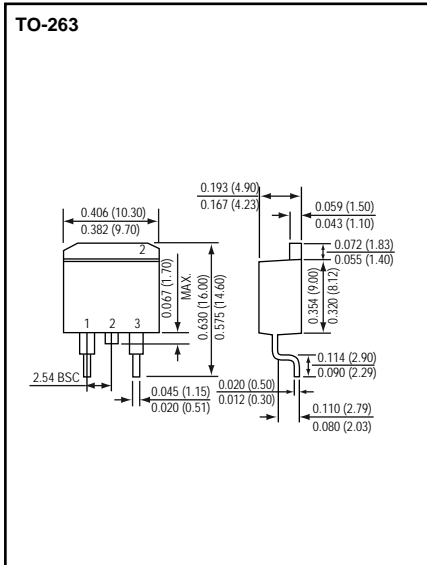
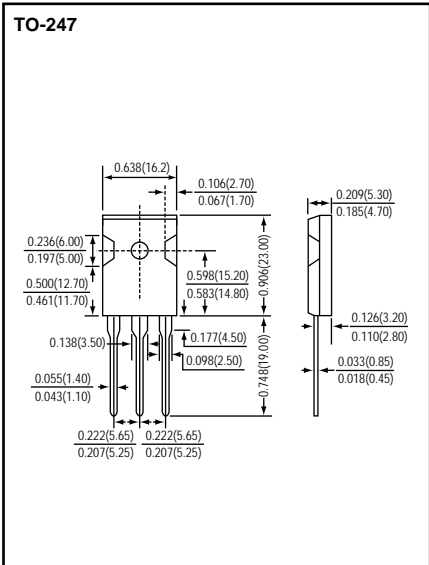

# CASE DRAWINGS

\*Dimensions in inches and (millimeters)

**GBPC**

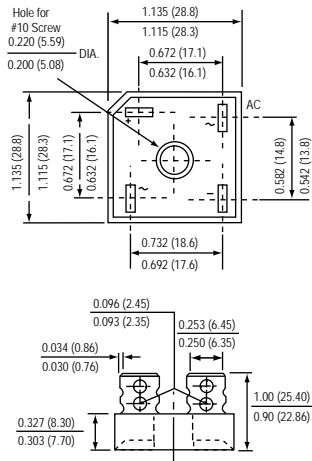

**GBPC-W**

