

THICK FILM RESISTOR NETWORKS

RA(RB) SERIES

Thick Film resistor networks SIP type have metal glaze elements on the ceramic substrates with strong clip-construction terminals, and are coated with special epoxy resin. They are originally designed, as a style of single in line package, and are the most suitable to meet the density of circuit assembling.

Features

- Small in size with high precision package. It is suitably used in printed circuit board.
- Automated machinery mass production and competitive prices accordingly.
- Extremely high stability, accuracy and reliability.

General Specification

Operating Temp. Range	- 55°C to ~ +125°C		Wattage/Element	RA		RB
T.C.R.	±100 ppm 50 ohm ~ 2.2 M ohm			B Circuits	Others	All Circuits
	±250 ppm < 50 ohm ~ > 2.2 M ohm		0.2W	0.125W	0.25W	
Rating Ambient Temp.	+70°C		Max. Working Voltage	100V		200V
Resistance Range (E-12 Series)	R Circuit	Others	Resistance Tolerance	F = 1% G = ± 2%, J = ± 5%		
	100Ω-10K	10Ω-4.7MΩ				

Internal Circuit

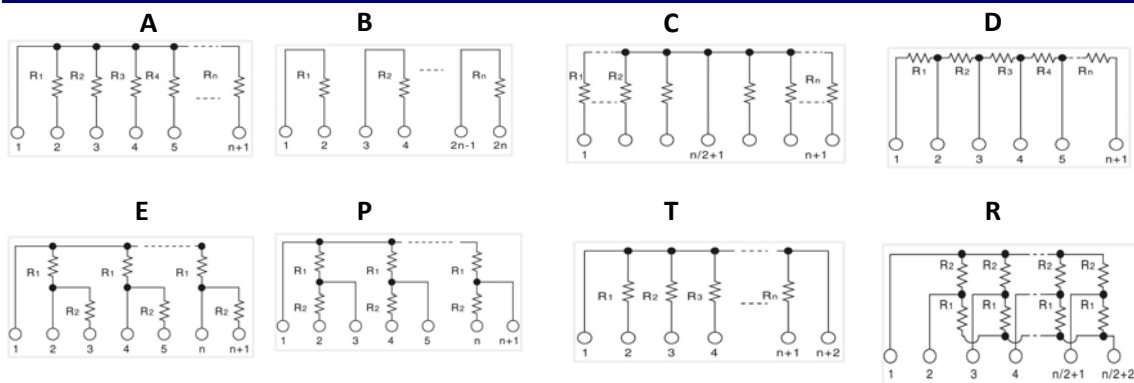

Dimensions (Standard Type)

Dual Terminators (R1/R2) (OHM)

DIMENSIONS

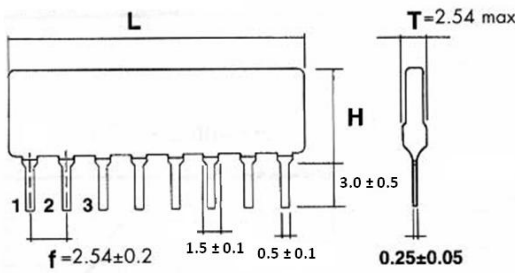

160/240	330/390
180/390	330/470
220/270	1.5K/3.3K
220/330	3.0K/6.2K

L											H MAX	
NO. PS											RA	RB
4	5	6	7	8	9	10	11	12	13	14	5.08	7.5
10.2 MM	12.7	15.3	17.8	20.4	22.1	25.4	28	30.5	33.1	35.6		

Derating Curve

Short Time Overload

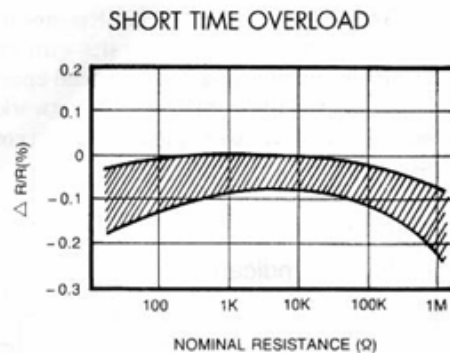
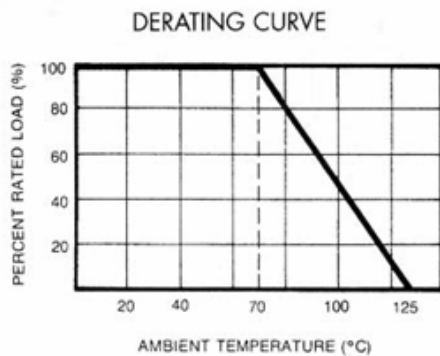

Characteristic Performance

Test Items	Specification
Insulation Resistance (200Vdc Applied)	10 ⁴ MΩ or Greater
Thermal Shock (-55°C to +125°C, 5 Cycles)	Δ R/R: ± (0.5% + 0.1 Ω)
Short Time Overload(2.5 X Rated Voltage, 5 Sec.)	Δ R/R: ± (0.5% + 0.1 Ω)
Resistance to Soldering Heat (+260°C ± 5°C, 10 sec)	Δ R/R: ± (0.5% + 0.1 Ω)
Head Shock (+25°C to +125°C, 5 Cycles)	Δ R/R: ± (0.5% + 0.1 Ω)
Moisture Resistance, Constant State (40°C, 95% R.H., 1000Hrs.)	Δ R/R: ± (1% + 0.1 Ω)
High Temperature Exposure (125°C, 100Hrs.)	Δ R/R: ± (1% + 0.1 Ω)
Moisture Load Life (1,000Hrs., 40°C, 95% R.H., - Rated Voltage Cycling)	Δ R/R: ± (3% + 0.1 Ω)
Load Life (1,000Hrs., Rated Voltage Cycling at 70°C)	Δ R/R: ± (3% + 0.1 Ω)
Load Pull Strength (1kg, 10Sec.)	Δ R/R: ± (0.5% + 0.1 Ω)
Temperature Coefficient (-55°C to 125°C)	± 100ppm/°C, ± 250ppm/°C for <50 Ω or > 2.2 M
Solderability (230°C for 5 Sec.)	95% min. coverage
Note: Test methods and conditions are in accordance with MIL-R-83401	



Marking

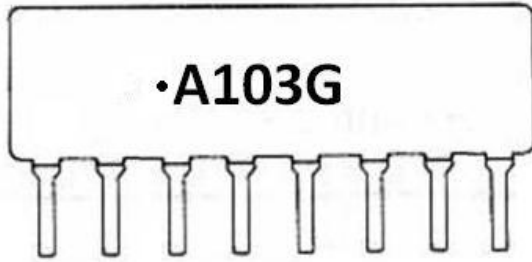

A : Type of Circuit
103 : Resistance Value, 3-digit code
G : Tolerance $\pm 2\%$

Parts Number System

RA	9	A	103	G
Single In-Line Resistor Network	No. of Pins	Circuit Type	Resistance Code	Resistance Tolerance
RA= Low profile RB= High profile	4 To 14	A, E B, P C, T D, R	3-digit Code 2%, 5%	F= $\pm 1\%$ G= $\pm 2\%$ J= $\pm 5\%$

